

TP M100 MOTORIZED VIP TURNSTILE



GENERAL INFORMATION

TP-M100 Series Motorized VIP Turnstile offers an alternative to regulate pedestrian traffic. Thanks to its 90 cm arm length, it complies with international disabled access standards.

It can be applied in shopping malls, supermarkets, fitness and wellness centers with its compact, aesthetic and user-friendly design.

MAIN CHARACTERISTICS

- Aesthetic outfit with satin finishing,
- Steel profile swing arm,
- Low maintenance requirement, long product life,
- Unidirectional motorized movement,
- Ease of integration with all access control equipment through its electronic control card.

TECHNICAL SPECIFICATION

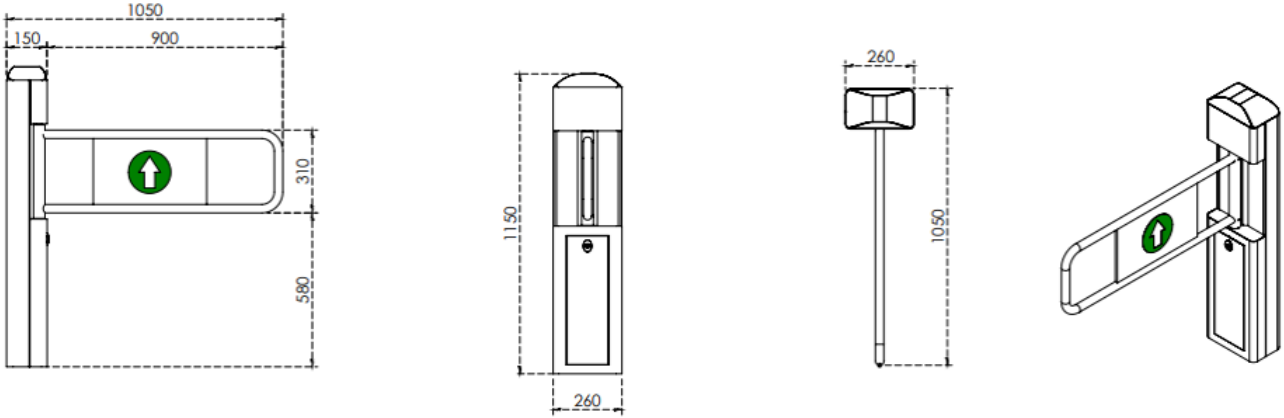

PHYSICAL CHARACTERISTICS

MAIN BODY	1,5 mm 304 grade stainless steel
DIMENSIONS	260mm x 1050mm x 1150 mm, (W x L x H)
TREATMENT	All other parts are coated against corrosion
CAPACITY	More than 30 passengers per minute
ACCESS CONTROL	Microprocessor based control for granting access. Easy integration with all kind of access control equipment
SWING ARM	Steel profile frame with 32 mm diameter, 900 mm arm length
OPERATING VOLTAGE	None, 115-240 VAC / 24 V DC, 50-60 Hz
SAFETY	Electrical and mechanical safety for all component. To avoid injuries, all corners and sides are rounded
INSTALLATION	Stainless steel modular installation platform/base
ACCESSORIES	Button Control (Optional), RF Receiver, RF Transmitter, RF Antenna (Optional)

CERTIFICATIONS AND WARRANTY

CERTIFICATIONS	ISO 9001:2015, ISO 14001:2015, OHSAS 18001, CE, TSE
WARRANTY	2 years